

Garage Jacks - Professional

- Professional range of premium quality quick lift jacks
- Tested to Australian standards
- Range in capacity from 2,000 to 2,500kg
- Suitable for professional user where performance and safety is paramount



Safety overload valve.
Up to 5t (optional)



Hydraulic stroke limitation



ARM800QL



ARM901QL

Features

- Quick lift dual pump pistons
- Fast no-load lift M800QL - 5 to 6 and M901QL - 6 to 7 full pumps
- High quality machined cylinders for leak free performance
- Ram and cylinder are polished to protect against internal abrasions
- Hydraulic stroke limitation system prevents the ram from being over extended and causing damage to the cylinder
- Fitted with removable saddle and handle pads to protect body work of vehicle being lifted
- High quality durable seals for extended service life

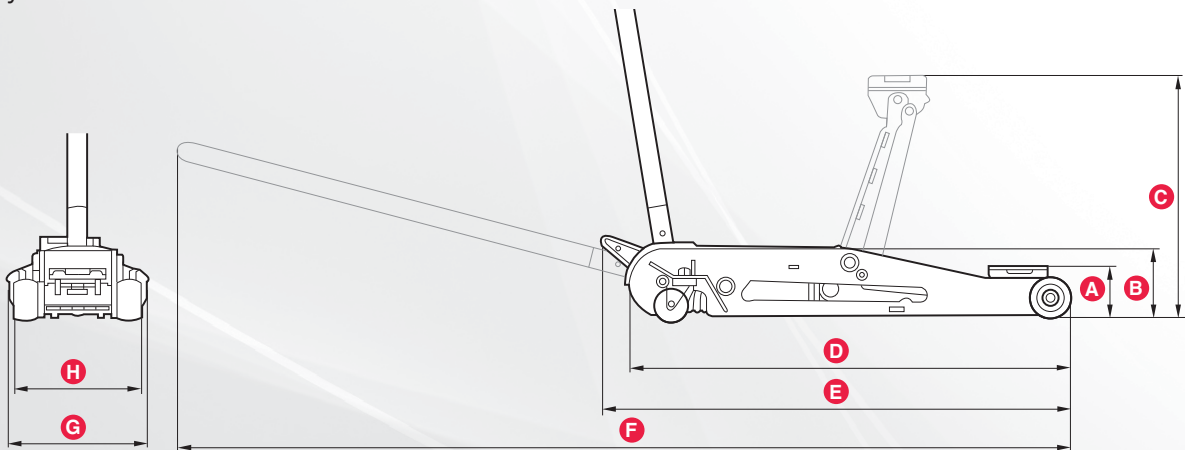
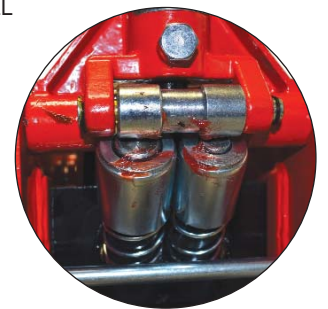

Part Number	Capacity (kg)	A	B	C	D	E	F	G	H	Weight (kg)
ARM800QL	2,000	130	165	470	640	695	1880	345	257	34.5
ARM901QL	2,500	102	165	520.7	711.2	770	1975	368.3	295	44.0

* Measurements in mm